



Air Conditioning & Heating

PRODUCT SPECIFICATIONS



10.3 EER

7½ TO 10 TON

COOLING CAPACITY: 86,000 - 116,000 BTU/H



* Full warranty details available at www.goodmanmfg.com.

PCC COMMERCIAL

PACKAGED AIR CONDITIONER

The PCC Commercial packaged air conditioner features combination electric heat/electric cooling with dual high-efficiency scroll compressors. This unit contains totally enclosed, permanently lubricated outdoor fan motors and is designed for over/under or downflow applications.

Standard Features

- Dual high-efficiency scroll compressors with internal motor protection for 2-stage cooling
- Totally enclosed, permanently lubricated outdoor fan motors
- Enhanced copper tube/aluminum fin coils
- Fully charged R-22 systems
- Belt-driven, variable-pitch sheave permits multi-speed adjustment
- Expansion valve evaporator coil
- Time delay for compressors sequence
- Compressor grommets for vibration isolation
- Two independent condenser coils for two-stage operation
- High- and low-pressure controls on all systems
- Mild ambient switch
- Centrifugal fan for quiet and efficient operation

Cabinet Features

- Heavy-gauge, zinc-coated steel cabinet with weather-resistant powder-paint finish
- Fully insulated with blankets of insulation
- Vertical discharge with removable grilles
- Control box and compressors easily accessible from side access panels
- Base rails with fork slots for convenience of handling and added rigidity
- Galvanized steel, powder-coated drain pan with ¾" NPT condensate connection
- Factory wiring conveniently arranged to install accessories
- Filters are provided with unit (2" disposable)
- When properly anchored, meets the 2001 Florida Building Code unit integrity requirements for hurricane-type winds



NOMENCLATURE

		PCC	120	3	A
		1, 2, 3	4	5	6
Unit Type	PCC Packaged Air Conditioner				
					Engineering Revisions
Nominal Capacity	090 90,000 BTU/h 120 120,000 BTU/h				
					Electrical 3 208-230/3/60 4 460/3/60

ACCESSORIES

THERMOSTAT (CHT90-120)

Two-stage cool / two-stage heat thermostat with subbase, manual changeover, fan-on or auto. **Note:** A variety of thermostat configurations can be used on this equipment based on the application needs. For example, our CHTS36-60 can be used if two-stage cooling and single-stage heating is desired.

ROOFTOP LIFT KIT (RLK90-120)

Kit consists of four ½” shackles that are used to lift the equipment into position on a roof, etc. The shackles are attached to the mounting holes in the base rails. Wire or strap material along with field-supplied spreader bars are employed to complete the lifting assembly (see rigging detail).

LOW AMBIENT CONTROL (LA-01)

Liquid temperature- (or pressure-) operated solid-state control that varies the speed of one of the condenser fans. Low ambient control reduces fan motor RPM as liquid temperature (or pressure) decreases. **Caution:** If control is used below 50 °F, accumulators should be added to the equipment to avoid slugging of the compressors.

ROOF CURB (PGC-5)

Full perimeter curb for equipment in the down discharge application. Curb includes provisions for duct attachment prior to setting unit. Curb is shipped knocked down with all necessary hardware and gasket material.

MANUAL AND MOTORIZED FRESH AIR DAMPERS (PGMD-5 & PGMDM-5)

Manual damper is fixed position type for 0% to 25% fresh air. Motorized damper is a field-adjustable mechanical damper for 0% to 25% fresh air. Damper automatically closes when blower stops.

ECONOMIZERS : (PGED090/102-5A & PGED120/180-5A, PGEH090/102-5 & PGEH120/180-5)

Fully modulating, enthalpy-controlled economizers shipped with major components pre-assembled. Plug assembly on equipment and economizer provides easy foolproof wiring.

HORIZONTAL DUCT KIT (PGHDK090/102-5A & PGHDK120/180-5A)

The unit is shipped in the downflow (vertical) duct configuration. The horizontal duct kit must be installed in the field for horizontal duct configuration.

PANEL LOUVER KIT (PLK090/102-5 & PLK120/180-5)

Louvered panels for condenser coil protection.

HEAT KIT ACCESSORY

Slide-in heat kit from 20kW, 30W and 40kW can be used in 7½- to 10-ton models.

SPECIFICATIONS

	PCC090-3A	PCC090-4A	PCC120-3A	PCC120-4A
Cooling Capacity				
Total BTU/h	86,000	86,000	116,000	116,000
Sensible BTU/h ¹	63,600	63,600	85,000	85,000
EER ²	10.3	10.3	10.3	10.3
IPLV ³	10.7	10.7	10.7	10.7
Indoor Blowers (2)				
Type	Belt	Belt	Belt	Belt
Wheel (D x W)	12" x 12"	12" x 12"	12" x 15"	12" x 15"
Indoor Nominal CFM	3,000	3,000	3,800	3,800
Horsepower	1½	1½	3	3
Evaporator Coil (1)				
Face Area (ft ²)	11.2	11.2	14	14
Rows Deep/ Fins per Inch	3/ 16	3/ 16	3/ 16	3/ 16
Tube Diameter - Material	¾" - Copper	¾" - Copper	¾" - Copper	¾" - Copper
Filter Size (ft ²) / Quantity	—	—	16 x 25 x 2 / 3	16 x 25 x 2 / 3
	25 x 25 x 2 / 3	25 x 25 x 2 / 3	20 x 25 x 2 / 3	20 x 25 x 2 / 3
Condenser Fans (2) / Coil (1)				
Horsepower	½	½	½	½
Fan Diameter	24"	24"	24"	24"
Outdoor Nominal CFM	5,500	5,500	6,400	6,400
Face Area (ft ²)	15.6	15.6	23.8	23.8
Rows Deep/ Fins per Inch	2/ 21	2/ 21	2/ 21	2/ 21
Tube Diameter - Material	¾" - Copper	¾" - Copper	¾" - Copper	¾" - Copper
Electrical Data				
Voltage-Phase	208/230-3	460-3	208/230-3	460-3
Compressor RLA/ LRA	12.5/ 88	5.9/ 44	17.4/ 123	6.8/ 49.5
Indoor Blower FLA	4.2	2.0	8.4	4.2
Outdoor Blower FLA	2.6	1.3	2.6	1.3
Min. Circuit Ampacity ⁴	38.1	18.2	54.5	22.5
Max. Overcurrent Device ⁵	60 amps	30 amps	70 amps	35 amps
Operating Weight (lbs)	980	980	1,270	1,270
Ship Weight (lbs)	1,000	1,000	1,290	1,290

¹ Sensible capacity is gross, with no deduction for indoor motor heat

² BTU/Watt @ 80/ 67° F inside; 95° F outside air

³ IPLV = Integrated Part Load Valve

⁴ Wire size should be determined in accordance with National Electrical Codes. Extensive wire runs will require larger wire sizes.

⁵ HACR breakers may be used in place of fuses up to 60 amps

DIMENSIONS

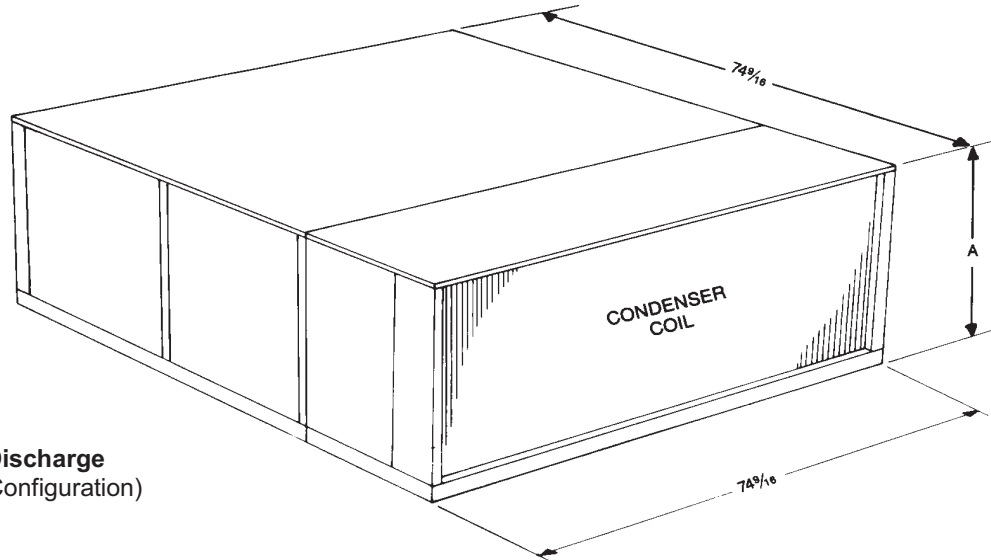

Vertical Discharge
(Factory Configuration)

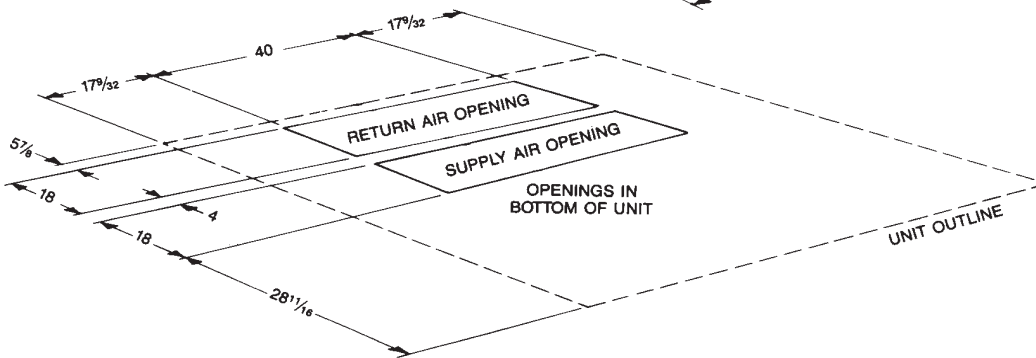

Horizontal Discharge
(With Field Installed
Accessory)

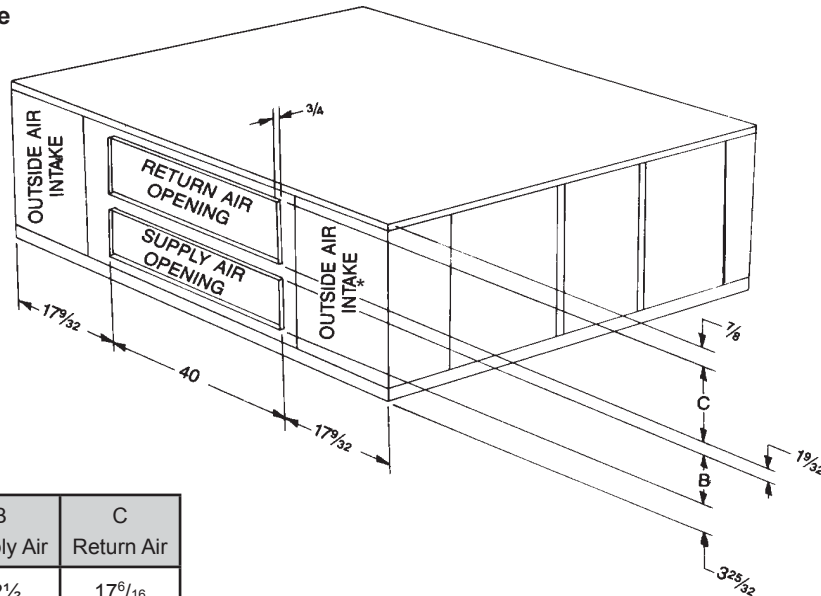

Unit Size	A Height	B Supply Air	C Return Air
PCC090-X	36	12 1/2	17 6/16
PCC120-X	52	20 1/4	25 13/16

X = Electrical Designation

DIMENSIONS—ELECTRICAL CONNECTIONS

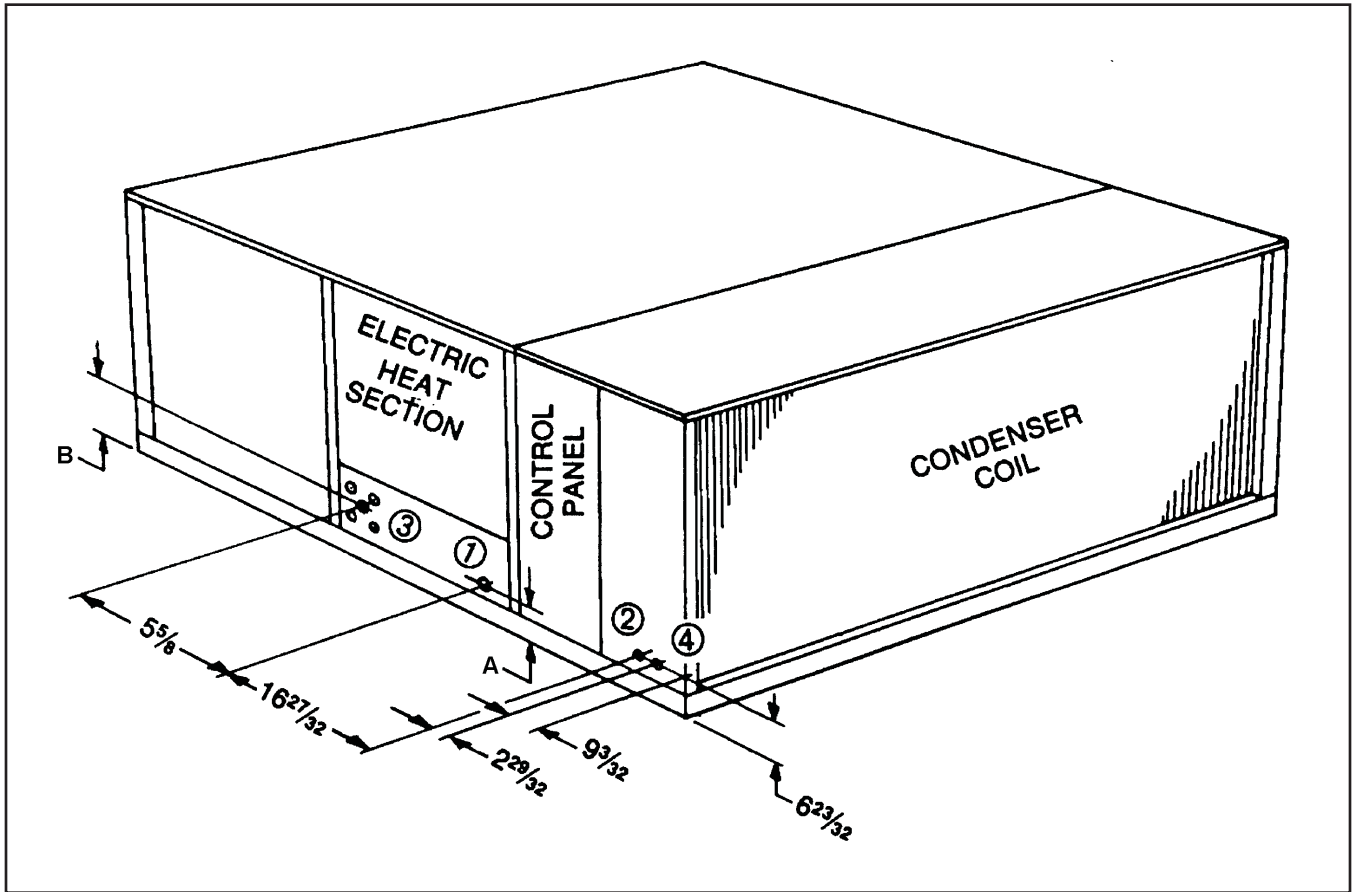

1. Main power entrance location
2. Control wiring entrance location
3. Optional field installed internal disconnect switch
4. Knockout not used on electric heat units

Model	A	B
PCC090-X	6 1/8	7 7/8
PCC120-X	22 1/8	23 7/8

X = Electrical Designation

COMPONENT PRESSURE DROPS

Model	CFM	Wet Coil	Electric Heat	Medium EFF. Filters	Economizer Return Air Damper
PCC090-X	2,600	0.06	0.03	0.03	0.14
	3,000	0.06	0.04	0.04	0.14
	3,400	0.07	0.05	0.05	0.18
PCC120-X	3,600	0.05	0.05	0.03	0.14
	4,000	0.05	0.06	0.04	0.14
	4,400	0.05	0.08	0.04	0.14

COOLING CAPACITY DATA — PCC090-X @ 3,000 CFM

AMB. °F	EVAP. EAT	75 °F DB			80 °F DB			85 °F DB			90 °F DB		
		KW	MBHT	MBHS	KW	MBHT	MBHS	KW	MBHT	MBHS	KW	MBHT	MBHS
85	61 WB	7.6	83.8	72.1	7.6	85.7	84.8	7.7	90.6	90.6	7.7	95.5	95.5
	64 WB	7.7	88.7	63.3	7.7	88.7	77.9	7.7	90.6	90.6	7.7	95.5	95.5
	67 WB	7.7	94.5	54.6	7.7	94.5	69.2	7.7	94.5	82.8	7.8	95.5	95.5
	70 WB	7.8	100.3	45.8	7.8	100.3	60.4	7.8	100.3	74.0	7.8	100.3	88.7
	73 WB	7.8	106.2	37.0	7.8	106.2	51.6	7.8	106.2	65.3	7.9	106.2	79.9
90	61 WB	7.8	81.8	71.1	7.9	83.8	83.8	8.0	88.7	88.7	8.0	94.5	94.5
	64 WB	8.0	86.7	62.4	8.0	87.7	77.0	8.0	88.7	88.7	8.0	94.5	94.5
	67 WB	8.1	92.5	53.6	8.1	92.5	68.2	8.1	92.5	82.8	8.1	94.5	94.5
	70 WB	8.1	97.4	44.8	8.1	97.4	59.4	8.1	98.4	74.0	8.2	98.4	87.7
	73 WB	8.2	103.3	36.0	8.2	103.3	50.7	8.2	105.2	64.3	8.4	103.3	78.9
95	61 WB	8.2	80.9	71.1	8.3	82.8	82.8	8.3	87.7	87.7	8.4	93.5	93.5
	64 WB	8.3	85.7	62.4	8.3	85.7	76.0	8.3	87.7	87.7	8.4	93.5	93.5
	67 WB	8.4	90.6	53.6	8.4	90.6	68.2	8.4	90.6	81.8	8.4	93.5	93.5
	70 WB	8.4	96.4	44.8	8.4	96.4	58.5	8.4	96.4	73.1	8.4	96.4	87.7
	73 WB	8.5	101.3	35.1	8.5	101.3	49.7	8.5	101.3	64.3	8.6	101.3	78.9
100	61 WB	8.5	78.9	70.1	8.6	80.9	80.9	8.6	86.7	86.7	8.7	91.6	91.6
	64 WB	8.6	83.8	61.4	8.6	83.8	76.0	8.6	86.7	86.7	8.7	91.6	91.6
	67 WB	8.7	88.7	52.6	8.7	88.7	67.2	8.7	88.7	80.9	8.7	91.6	91.6
	70 WB	8.8	94.5	43.8	8.8	94.5	58.5	8.8	94.5	72.1	8.8	94.5	85.7
	73 WB	8.9	99.4	35.1	9.0	99.4	48.7	9.0	99.4	63.3	9.0	99.4	77.9
105	61 WB	8.9	77.0	69.2	8.9	79.9	79.9	9.0	84.8	84.8	9.1	89.6	89.6
	64 WB	8.9	81.8	60.4	8.9	81.8	75.0	9.0	84.8	84.8	9.1	89.6	89.6
	67 WB	9.1	86.7	51.6	9.1	86.7	66.3	9.1	86.7	79.9	9.1	89.6	89.6
	70 WB	9.1	91.6	42.9	9.1	91.6	57.5	9.2	92.5	71.1	9.2	92.5	85.7
	73 WB	9.4	98.4	34.1	9.4	98.4	48.7	9.4	98.4	62.4	9.4	98.4	77.0

NOTES:

- Capacities are gross and are based on 230, 460 operation. 208-volt operation must be derated by 0.98. Gross capacities do not include evaporator motor heat.
- kW is for entire unit
- See table for capacity correction factors at other than nominal CFM.

■ SHADED AREA REPRESENTS 100% SENSIBLE COOLING

- AMB Ambient Air Temperature
- EAT Entering Air Temperature
- DB Evaporator Dry Bulb EAT
- WB Evaporator Wet Bulb EAT
- CFM Evaporator Airflow Ft.³/min (Table 9a)
- kW 1,000 Watts
- MBHT 1,000 BTU/h Total Cooling
- MBHS 00 BTU/h Sensible Cooling

COOLING CAPACITY DATA (CONT.) — PCC120-X @ 4,000 CFM

AMB. °F	EVAP. EAT	75 °F DB			80 °F DB			85 °F DB			90 °F DB		
		KW	MBHT	MBHS	KW	MBHT	MBHS	KW	MBHT	MBHS	KW	MBHT	MBHS
85	61 WB	10.2	115.9	99.7	10.2	118.6	117.2	10.3	125.3	125.3	10.3	132.0	132.0
	64 WB	10.3	122.6	87.6	10.3	122.6	107.8	10.3	125.3	125.3	10.3	132.0	132.0
	67 WB	10.3	130.7	75.4	10.3	130.7	95.6	10.3	130.7	114.5	10.5	132.0	132.0
	70 WB	10.6	138.8	63.3	10.6	138.8	83.5	10.6	138.8	102.4	10.6	138.8	122.6
	73 WB	10.6	146.9	51.2	10.6	146.9	71.4	10.6	146.9	90.3	10.7	146.9	110.5
90	61 WB	10.6	113.2	98.3	10.7	115.9	115.9	10.8	122.6	122.6	10.8	130.7	130.7
	64 WB	10.8	119.9	86.2	10.8	121.3	106.4	10.8	122.6	122.6	10.8	130.7	130.7
	67 WB	10.9	128.0	74.1	10.9	128.0	94.3	10.9	128.0	114.5	10.9	130.7	130.7
	70 WB	10.9	134.7	62.0	10.9	134.7	82.2	10.9	136.1	102.4	11.0	136.1	121.2
	73 WB	11.0	142.8	49.8	11.0	142.8	70.1	11.0	145.5	88.9	11.3	142.8	109.1
95	61 WB	11.0	111.8	98.3	11.1	114.5	114.5	11.1	121.3	121.2	11.3	129.3	129.3
	64 WB	11.1	118.6	86.2	11.1	118.6	105.1	11.1	121.3	121.2	11.3	129.3	129.3
	67 WB	11.3	125.3	74.1	11.3	125.3	94.3	11.3	125.3	113.2	11.4	129.3	129.3
	70 WB	11.3	133.4	62.0	11.4	133.4	80.8	11.4	133.4	101.0	11.4	133.4	121.2
	73 WB	11.5	140.1	48.5	11.5	140.1	68.7	11.5	140.1	88.9	11.6	140.1	109.1
100	61 WB	11.5	109.1	97.0	11.6	111.8	111.8	11.6	119.9	119.9	11.7	126.6	126.6
	64 WB	11.6	115.9	84.9	11.6	115.9	105.1	11.6	119.9	119.9	11.7	126.6	126.6
	67 WB	11.7	122.6	72.7	11.7	122.6	93.0	11.7	122.6	111.8	11.7	126.6	126.6
	70 WB	11.8	130.7	60.6	11.8	130.7	80.8	11.8	130.7	99.7	11.8	130.7	118.5
	73 WB	12.0	137.4	48.5	12.2	137.4	67.4	12.2	137.4	87.6	12.2	137.4	107.8
105	61 WB	12.0	106.4	95.6	12.0	110.5	110.5	12.2	117.2	117.2	12.3	124.0	123.9
	64 WB	12.0	113.2	83.5	12.0	113.2	103.7	12.2	117.2	117.2	12.3	124.0	123.9
	67 WB	12.3	119.9	71.4	12.3	119.9	91.6	12.3	119.9	110.5	12.3	124.0	123.9
	70 WB	12.3	126.6	59.3	12.3	126.6	79.5	12.4	128.0	98.3	12.4	128.0	118.5
	73 WB	12.6	136.1	47.2	12.6	136.1	67.4	12.6	136.1	86.2	12.6	136.1	106.4

NOTES:

- Capacities are gross and are based on 230, 460 operation. 208-volt operation must be derated by 0.98. Gross capacities do not include evaporator motor heat.
- kW is for entire unit
- See table for capacity correction factors at other than nominal CFM.

- AMB Ambient Air Temperature
- EAT Entering Air Temperature
- DB Evaporator Dry Bulb EAT
- WB Evaporator Wet Bulb EAT
- CFM Evaporator Airflow Ft.³/min (Table 9a)
- kW 1,000 Watts
- MBHT 1,000 BTU/h Total Cooling
- MBHS 00 BTU/h Sensible Cooling

SHADED AREA REPRESENTS 100% SENSIBLE COOLING

COOLING CAPACITY CORRECTION FACTORS

	CFM						
	-15%	-10%	-5%	STD.	+5%	+10%	+15%
Total MBH	0.971	0.985	0.991	0	1.006	1.012	1.019
Sensible MBH	0.925	0.952	0.974	0	1.024	1.048	1.070
kW	0.985	0.989	0.995	0	1.004	1.006	1.011

EVAPORATOR MOTOR HEAT

Horse-power	BTU/h
1.5	4,650
3	9,300

ELECTRIC HEAT AIR TEMPERATURE RISE

Heater Model		HKCB20	HKCB30	HKCB40
Number of Stages		2	2	2
Output (MBH)		67.9	135.8	135.8
CFM	2,600	24.2	36.2	-
	2,800	22.5	33.6	-
	3,000	21.0	31.4	-
	3,200	19.7	29.4	39.3
	3,400	18.5	27.7	37.0
	3,600	17.5	26.2	34.9
	3,800	16.5	24.8	33.1
	4,000	15.7	23.5	31.4
	4,200	15.0	22.4	29.9
	4,400	14.3	21.4	28.6
	4,600	13.7	20.5	27.3
	4,800	13.1	19.6	26.2
	5,000	12.6	18.8	25.2
	5,200	12.1	18.1	24.2
	5,400	11.6	17.4	23.3
	5,600	11.2	16.8	22.5
5,800	10.8	16.2	21.7	
6,000	10.5	15.7	21.0	

Notes

- Maximum air temperature rise of 40° must not be exceeded.
- See table for Electric Heat Kit Availability in various unit sizes.
- Air temperature rise is for total heating capacity. Temperature rises at other conditions may be calculated by using the formula:

$$\text{Temperature Rise} = \frac{\text{Output Capacity} - \text{BTU/h}}{1.08 \times \text{ft}^3/\text{min. Airflow}}$$
- For altitudes over 2,000', air temperature rise must be calculated using the formula:

$$\text{Temperature Rise} = \frac{\text{Output Capacity} - \text{BTU/h}}{14.4 \times \text{ft}^3/\text{Min. Airflow} \times \text{Specific Weight of Air}}$$
- Operation at less than nominal voltages must be derated by the following factors:
 460 volt-0.92; 230 volt-0.92; 208 volt-0.75.

HEAT KIT AVAILABILITY

Unit Size	HKCB20	HKCB30	HKCB40
7½	X	X	X
10	X	X	X

X - Heat Kit Available
 N/A - Heater Not Available

FAN PERFORMANCE DATA

PCC090-3/4

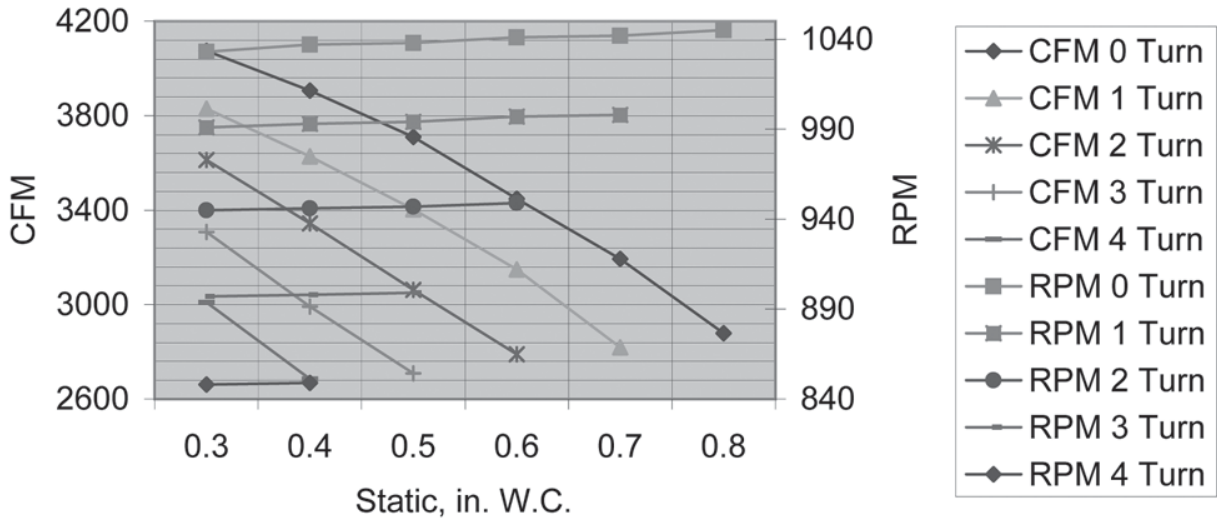

PCC120-3/4

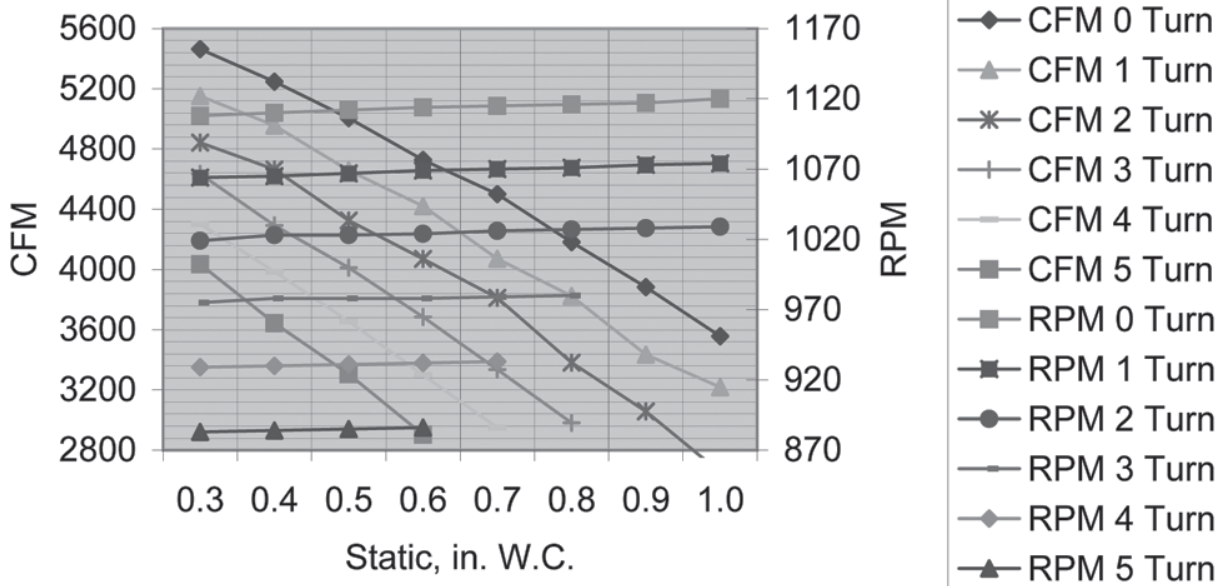

WIRING DIAGRAM — PCC24-36***

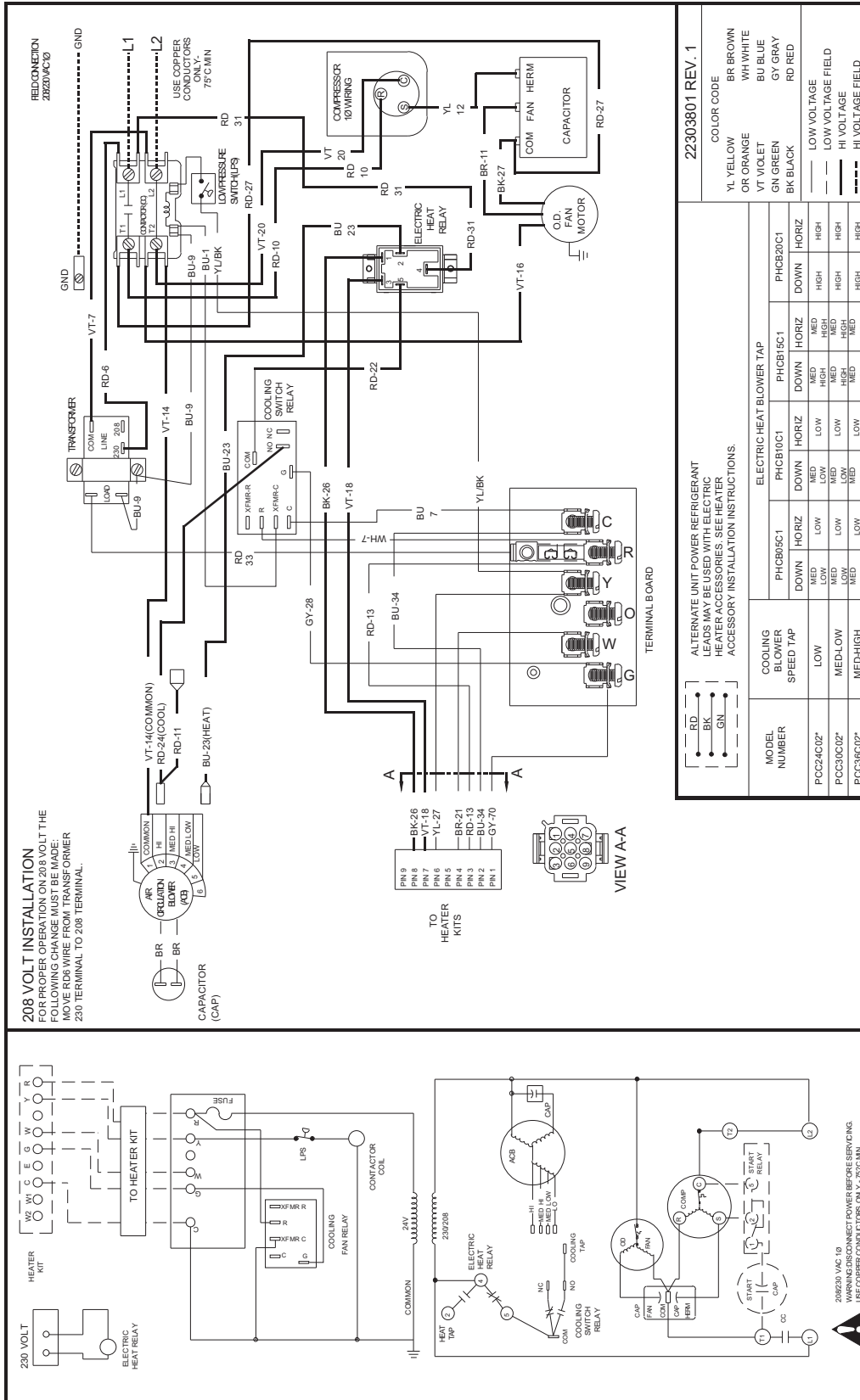

High Voltage: Disconnect all power before servicing or installing this unit. Multiple power sources may be present. Failure to do so may cause property damage, personal injury, or death.

WARNING

Wiring is subject to change. Always refer to the wiring diagram on the unit for the most up-to-date schematic.

WIRING DIAGRAM — PCC42-48***

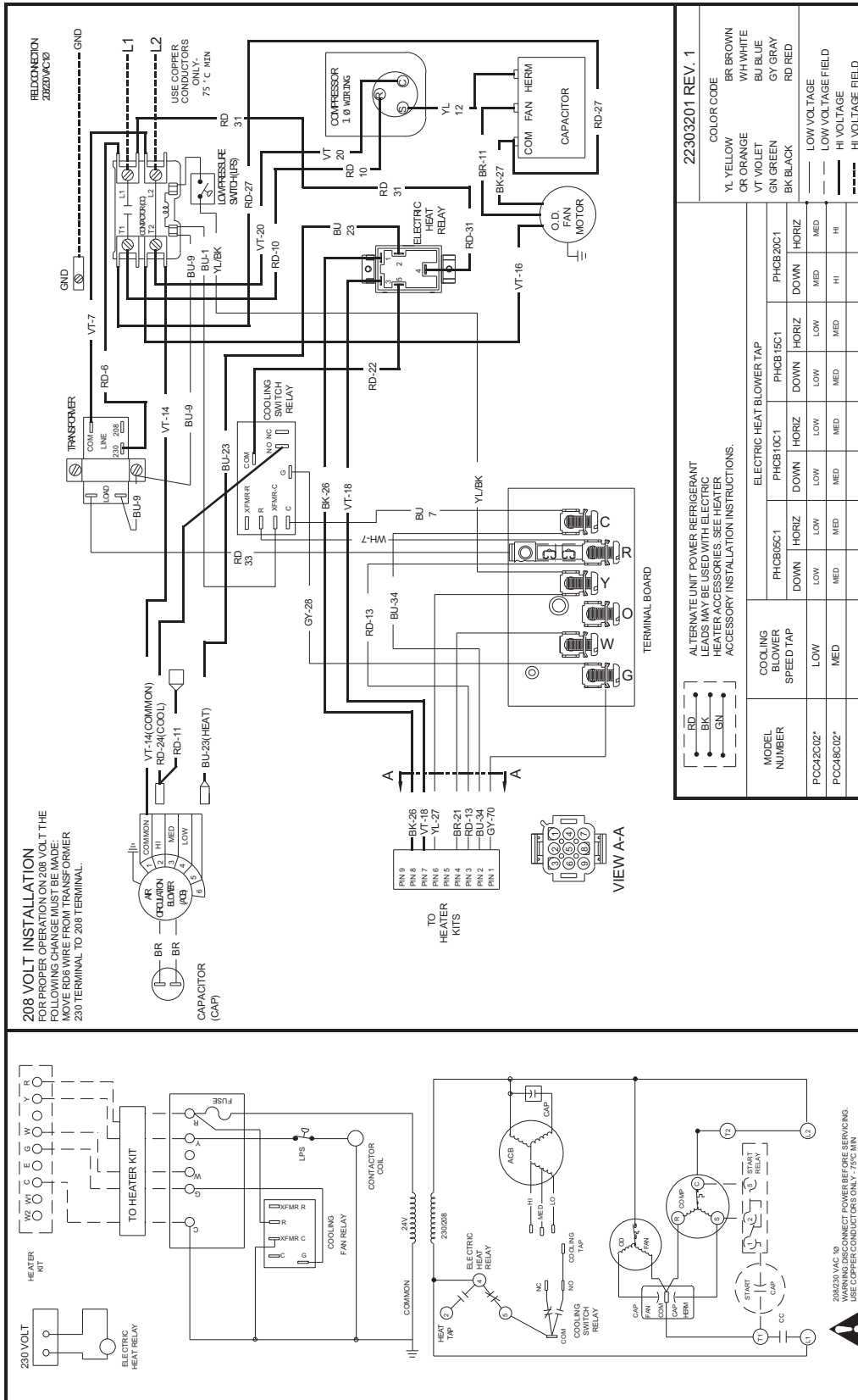

High Voltage: Disconnect all power before servicing or installing this unit. Multiple power sources may be present. Failure to do so may cause property damage, personal injury, or death.

WARNING

Wiring is subject to change. Always refer to the wiring diagram on the unit for the most up-to-date schematic.

WIRING DIAGRAM — PCC60***

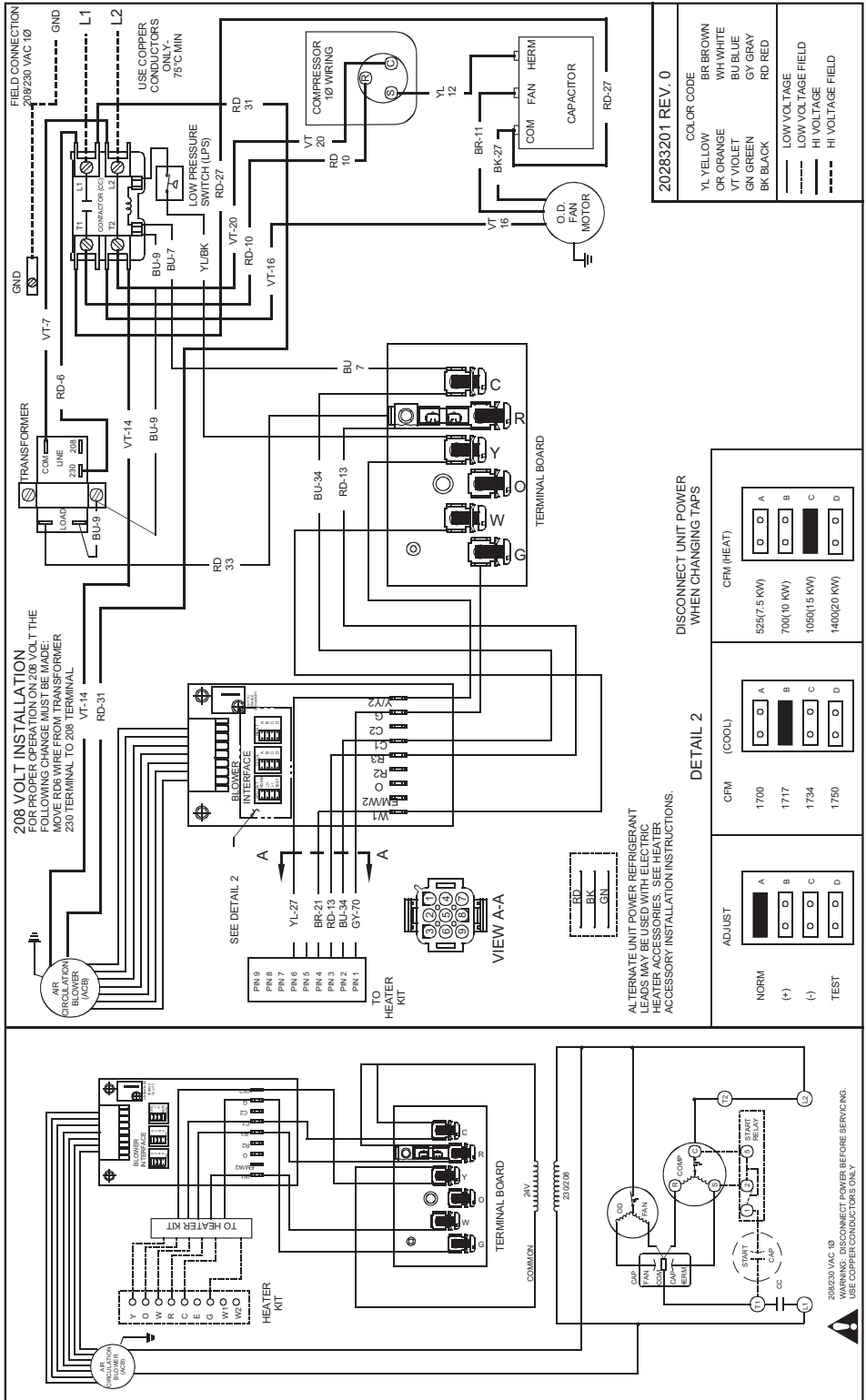

High Voltage: Disconnect all power before servicing or installing this unit. Multiple power sources may be present. Failure to do so may cause property damage, personal injury, or death.



Wiring is subject to change. Always refer to the wiring diagram for the unit for the most up-to-date schematic.

